

hSS Engineering

The International Master Distributor for **WHELEN**

WPS 4000 SERIES HIGH POWER VOICE & SIREN SYSTEM

INSTALLATION MANUAL

The information contained herein is proprietary to hss Engineering ApS and Whelen Engineering Company, Inc. No part of this manual may be reproduced, recorded or stored in a retrieval system, or transmitted, in any form without prior permission of hss Engineering ApS and Whelen Engineering Company, Inc.

The software described in this manual is supplied with the understanding that it may not be copied or otherwise redistributed without prior permission of hss Engineering ApS and Whelen Engineering Company, Inc.

All materials and specifications contained in this document are subject to change without notice.

Table of Contents

Important Note to the Installation Technicians.....	3
Section I:.....	4
Section II:	5
Section III:.....	7
a) Electronic Cabinet Mounting and Siren Connections Mounting	7
b) Siren Assembly Mounting	9
c) Antenna Mounting (optional).....	10
d) Solar Panel Mounting (optional).....	11
e) Determining Solar Panel Mounting Angle.....	14
Section IV:.....	15
a) Siren Connections	15
b) AC Wiring.....	17
c) Batteries.....	18
d) Landline (optional).....	19
Section V:	20
System Test	20

Illustrations:

Fig. 1: Sample Station Dwg (AC Powered Battery Charger).....	1
Fig. 2: Sample Station Dwg (Optional Solar Powered Battery Charger)	2
Fig. 3: Type II Electronic Cabinet Dimensions.....	5
Fig. 4: Antenna Mounting Bracket Dimensions	6
Fig. 5: Electronic Cabinet Mounting (Side View).....	7
Fig. 7: Solar Panel Wiring Connections	12
Fig. 8: Solar Panel Mounting Views	13
Fig. 9: Rotor Control and Siren Amplifier Connections.....	16
Fig. 10: AC Outlet Installation	18
Fig. 11: Battery Connections (Type II Cabinet)	18
Fig. 12: Landline Wiring.....	19
Fig. 13: System LED Diagnostic Indicators	21
Fig. 14: Electronic Cabinet Front Panel (Type II)	22

Fig. 1: Sample Station Dwg (AC Powered Battery Charger)

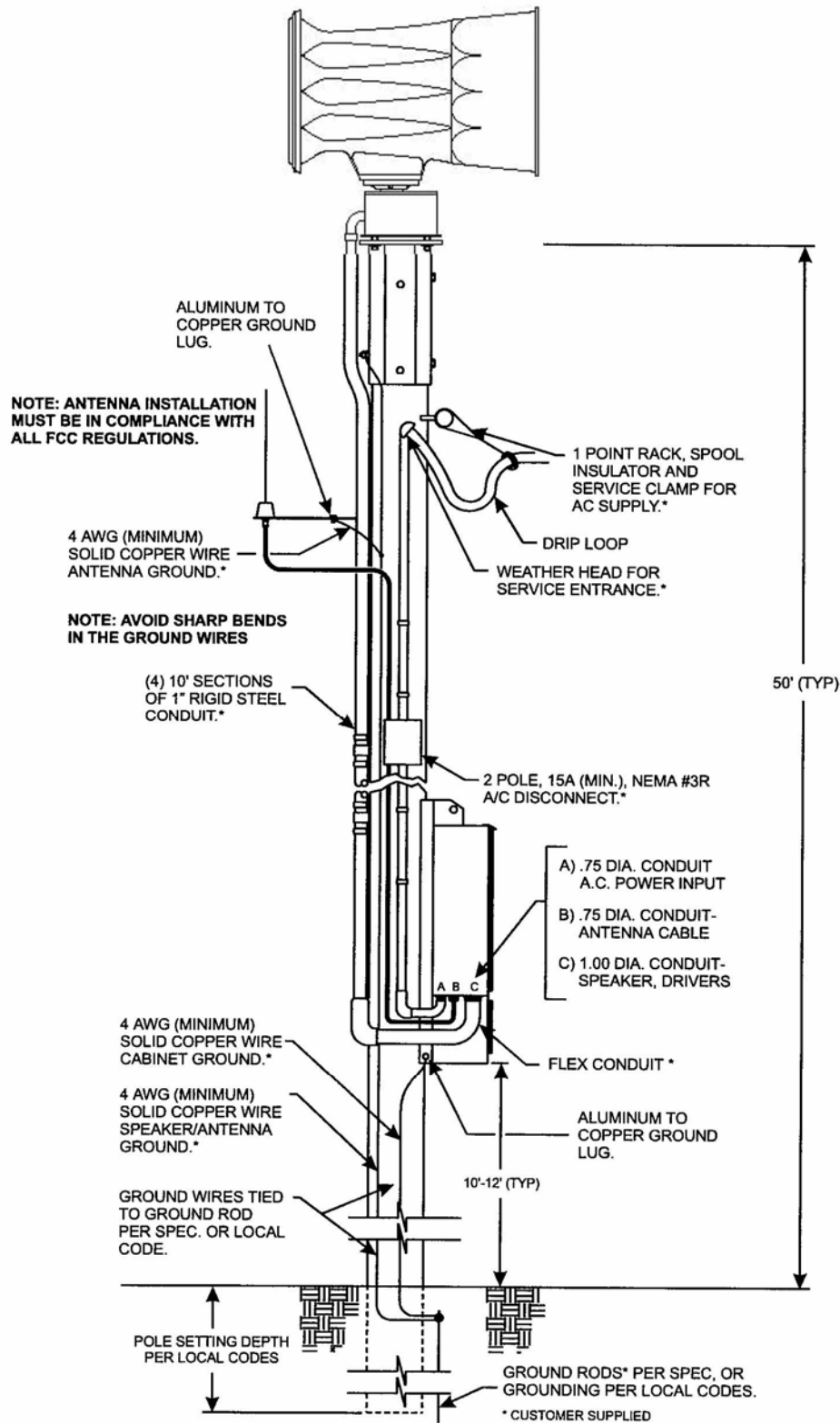
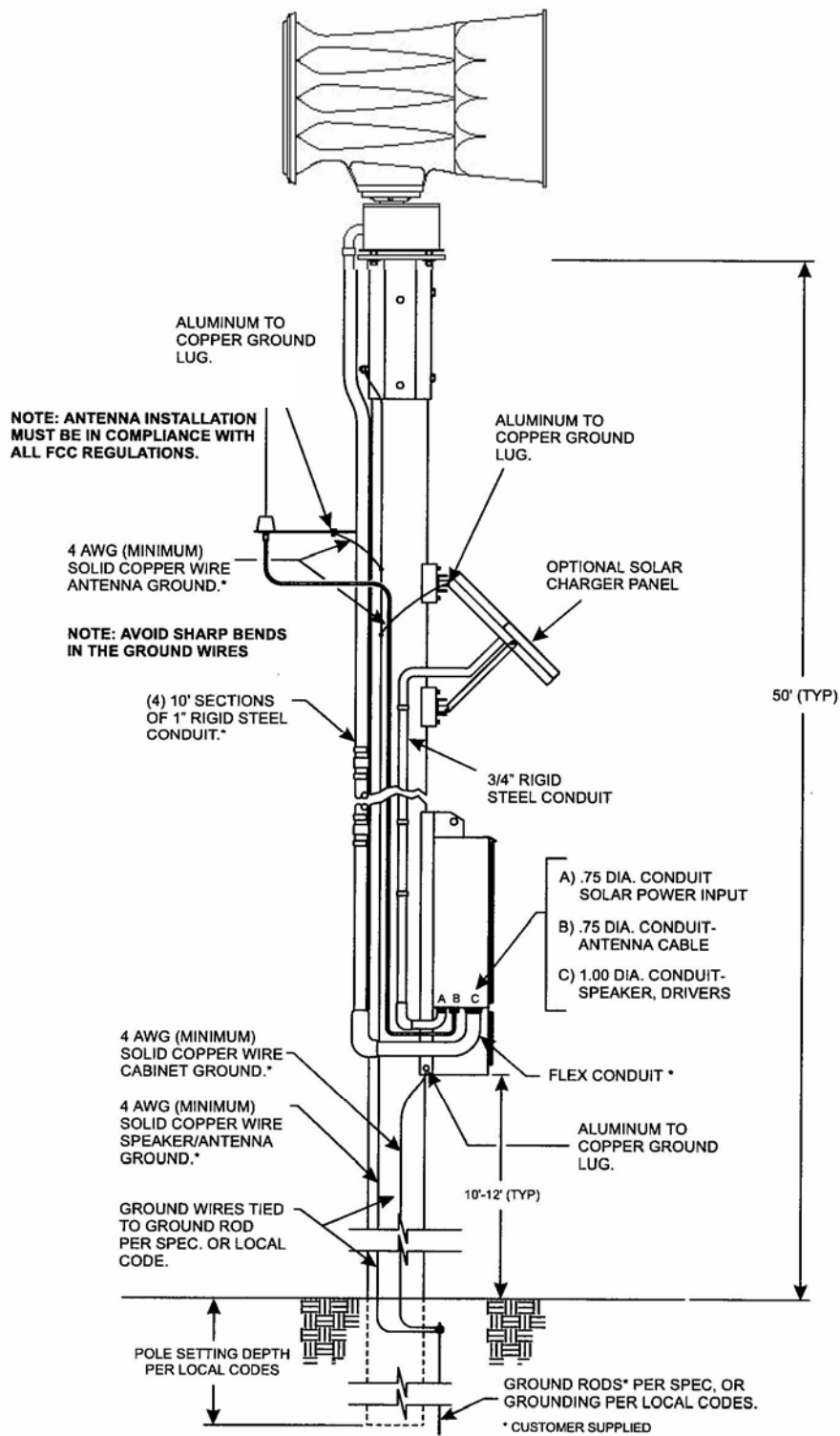

Fig. 2: Sample Station Dwg (Optional Solar Powered Battery Charger)



Important Note to the Installation Technicians

The installation of this product requires careful planning and attention to detail! The installation of this system should NOT be attempted by individuals without experience in the disciplines necessary to this procedure (i.e. high-voltage electrical wiring, utility pole installation, etc.).

The installation of the WPS4000 Series siren station provided in this manual follows a logical progression. This process is not arbitrary and was developed using information gathered from both the manufacturer and experienced field technicians. Deviations from any of these procedures are not recommended unless they are in contradiction with local codes. **IN ALL INSTANCES, LOCAL CODES TAKE PRECEDENT OVER PROCEDURES OUTLINED HEREIN.**

It is the responsibility of the installation technicians to read this entire manual. The installation procedure should not begin until all personnel are familiar with the entire process. The overall process includes the following:

Installation Sequence

1. Site Selection
2. Mounting of Electronic Cabinet
3. Prepare and Mount Antenna
Assembly (if present)
4. Prepare and Mount Solar Panels and
Conduit (if present)
5. Installation of AC or Solar Service
and Batteries
6. Confirm Proper System Operation

Section I:

Site Selection

The site selection for the WPS4000 Series siren requires careful consideration in order to achieve the optimum coverage of the siren station. For a guideline to system planning, sound propagation and site selection we direct the user to the Federal Emergency Management Agency's "Outdoor Warning Systems Guide, CPG 1-17."

The location of the siren site should be reviewed for its compatibility with its surroundings such as private homes, schools and hospitals. The user is cautioned to consider the use of hearing protection devices for service personnel working in close proximity to the speaker cluster.

Access to the siren site is important from the standpoint of service, maintenance inspection and access to a utility service connect.

Site locations for radio controlled units should be reviewed for radio reception.

Section II:

Fig. 3: Type II Electronic Cabinet Dimensions

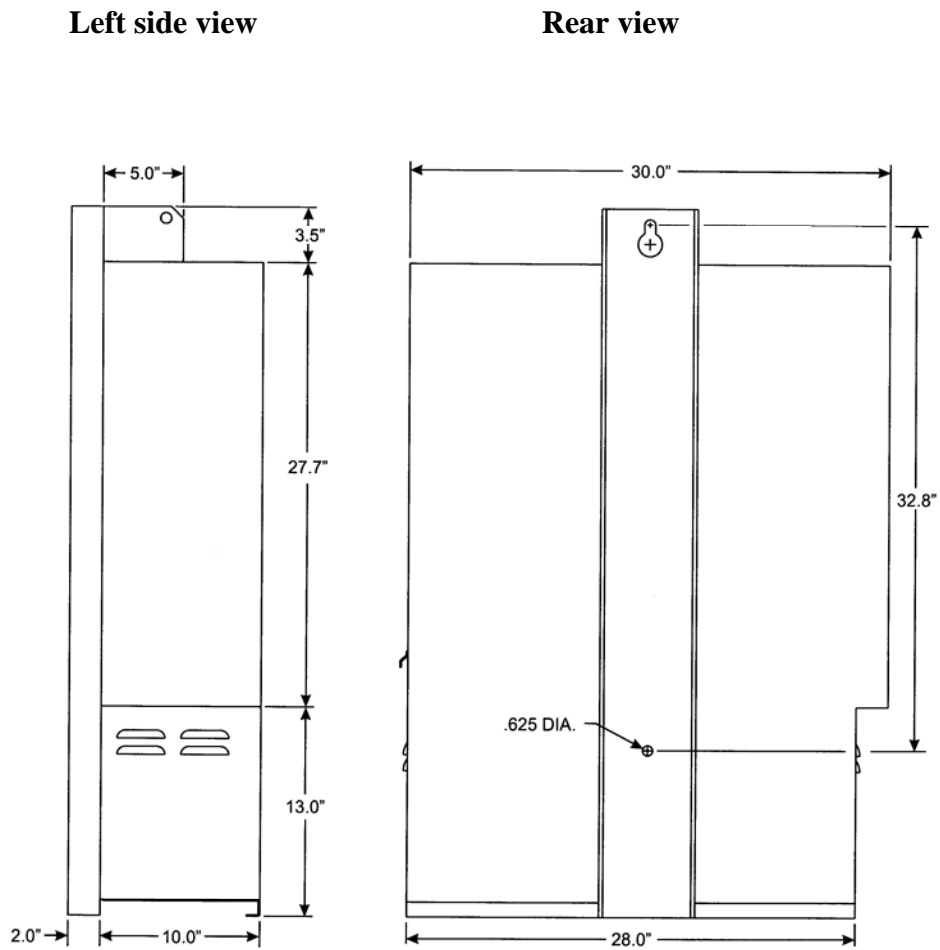
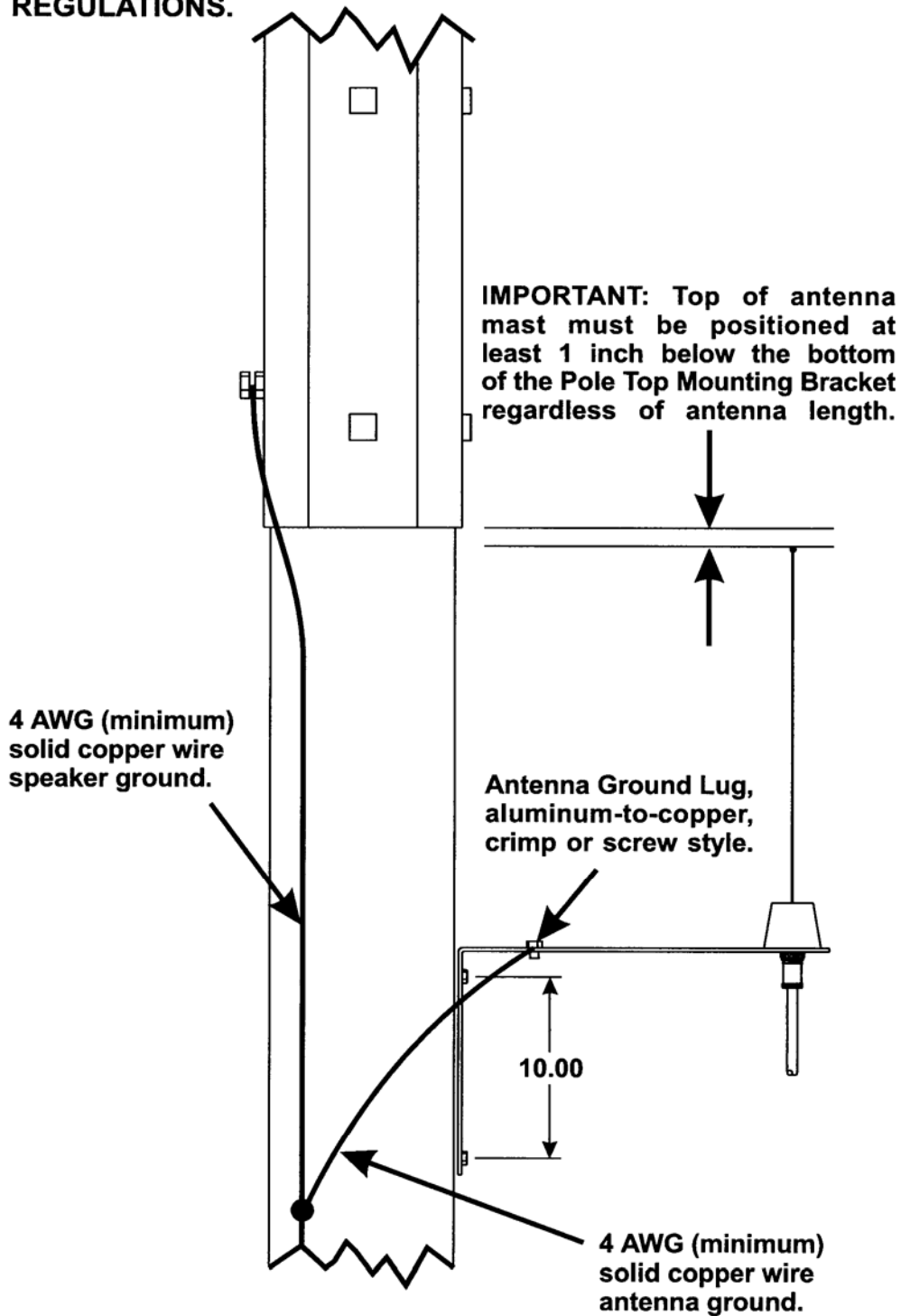

Fig. 4: Antenna Mounting Bracket Dimensions

NOTE: Antenna installation must be in compliance with all FCC REGULATIONS.



Section III:

a) Electronic Cabinet Mounting and Siren Connections Mounting

Items required for installation (not included):

For Type II cabinets

Qty.

<u>(Type II)</u>	<u>Description</u>
(2)	5/8" x 14" Hex or square head mounting bolts
(4)	5/8" Flat washer sized for the above mounting bolt
(2)	5/8" Split-lock washer
(2)	5/8" Hex or square head nuts
(1)	Aluminum-to-copper lug sized for #4 ground wire (crimp or screw style)
(1)	Stainless steel 1/4-20 x 2" bolt with appropriately sized flat washer, split-lock washer and nut
(1)	10' copper ground rod

Fig. 5: Electronic Cabinet Mounting (Side View)

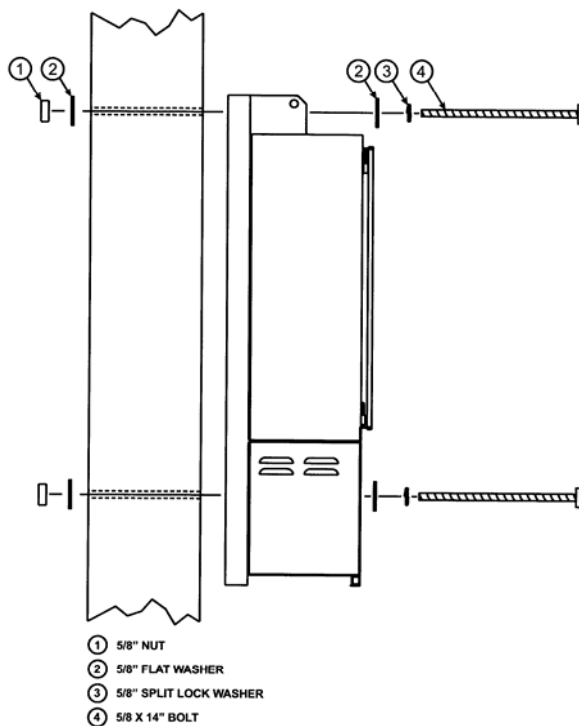

The WPS4000 Series case assembly may be installed onto the pole and wired before setting the pole.

NOTE:

Due to the weight of the siren amplifier panel, the electronic cabinet assembly must be transported in an upright fashion to prevent distortion of the amplifier panel.

1. It is necessary for the installer to remember that two factors should determine the optimum mounting location; the desired distance of the mounted cabinet to the ground (typically 10 to 12 feet as measured from the bottom of the cabinet) and available speaker wire length (speaker assemblies are provided with a minimum of 50 feet of speaker wire as measured from the bottom of the speaker assembly).
2. After the mounting location has been determined, drill an appropriately sized thru-hole into the pole at the top cabinet mounting hole. Install a bolt loosely into the hole and hang the cabinet onto the bolt.
3. With the cabinet fitted snugly to the pole, mark the surface of the pole at the lower mounting hole location inside the battery storage compartment. Remove the cabinet from the pole and drill an appropriately sized thru-hole into the pole at the location(s) marked. Return the cabinet to its mounting location and secure to the pole using the specified hardware.
4. Install an aluminum-to-copper lug (crimp or screw style) onto the #4 solid copper wire. Secure this to the cabinet mounting channel in the hole supplied using stainless steel 1/4 – 20 hardware.
5. Install the ground rod as specified by local codes and connect both copper wires (from mounting bracket and electronic cabinet) to this rod.
6. Install rigid steel conduit and necessary coupling from the speaker's 1" conduit adapter to the 1" speaker conduit protruding from the base of the siren case assembly. The first section of conduit may be installed onto the speaker's base casting prior to mounting the speaker to the mounting bracket. At the option of the user, conduit unions may be used between the first section of conduit and the speaker base casting and at the speaker cable conduit entrance to the siren case assembly.

NOTE:

If the location of the conduit on the pole requires difficult conduit bends or couplings, a section of metal bonded seal tight conduit NOT TO EXCEED 24 INCHES may be used at the top of the pole and/or at the bottom of the pole as needed for the speaker cable installation.

Batteries for the system should not be installed until the siren station is set in place, otherwise some leakage of the battery fluid may occur. Batteries should not be

connected to the system until AC power (or solar power if equipped) is available to the system to operate the system's battery charger.

b) Siren Assembly Mounting

Hardware required for installation (factory included):

(8)	20 mm hex head nuts
(8)	7/8" flat washers
(4)	3/4" split lock washers

1. Mount the speaker/rotator assembly to the pole bracket. Secure the rotor assembly to the pole using the hardware provided.
2. Sling or cradle the utility pole/mast in a safe manner so that the pole top is 3 to 4 feet off the ground. This will allow the speaker assembly to clear the ground when installed.
3. Locate the 4 mounting studs on the bottom of the speaker assembly.
4. Thread a 20 mm hex nut onto each of the mounting studs until there is approximately 1" of space between the top of the nuts and the bottom of the siren assembly. This space will allow the speaker assembly to be leveled once the pole has been set.
5. Install a 7/8" flat washer onto each of the mounting studs.
6. Insert the four mounting studs through the appropriately drilled holes in mounting bracket. The bottom of the siren assembly should lie flat against the mounting bracket.
7. Install a 7/8" flat washer onto each of the mounting studs.
8. Install a 3/4" split-lock-washer onto each of the mounting studs.
9. Thread a 20 mm hex nut onto each of the mounting studs. Tighten this nut firmly to secure the siren assembly to the mounting bracket.

At this point the pole/mast may now be set. However, the installer may use their own discretion as to whether to mount the electronic cabinet onto the utility pole/mast before the pole/mast is set.

NOTE:

When setting the pole, it is important to make sure to rotate the pole so that the speakers are pointed North.

When the pole/mast has been set, use the adjustment nuts to adjust the siren assembly until it is level.

c) Antenna Mounting (optional)

NOTE:

Antenna installation must be in compliance with all FCC regulations.

The proper antenna bracket mounting location is determined by several considerations. The antenna bracket should be positioned as high on the utility pole as is possible. However, under no circumstances should the top of the installed antenna must be any closer than one inch from the bottom of the Mounting Bracket (see “Fig. 4 Antenna Mounting Bracket Dimensions” on page 6). Be sure to ground the antenna bracket as shown using 4 AWG solid copper wire. The antenna cable provided by the factor is 35 feet in length.

It is also important to remember that the antenna **MUST** be mounted on the side of the utility pole/mast that faces the transmitter (see Fig.7).

Fig. 6: Antenna Mounting Orientation

Improper Antenna Orientation

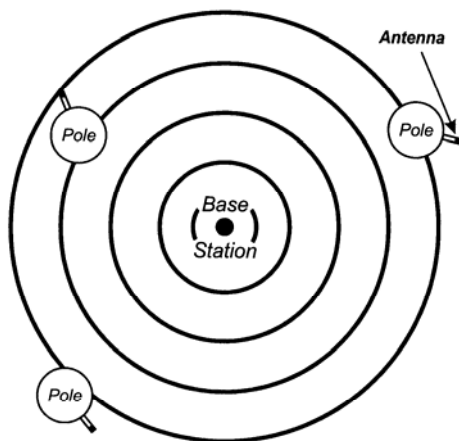

Correct Antenna Orientation

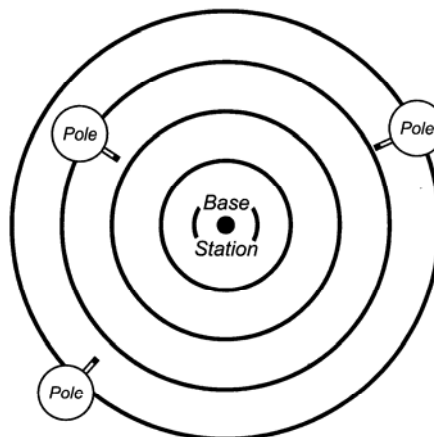

Refer to the installation sheet included with your antenna kit for further information regarding cable connections and antenna trimming.

d) Solar Panel Mounting (optional)

The solar panel must be installed so that it is directly facing the earth's equator with an unobstructed view. Failure to orient the solar panel in this way will result in significantly reduced charging effectiveness.

The most critical aspect of properly mounting the solar panel involves achieving the optimum tilt angle. The tilt angle is determined by the distance between the upper and lower mounting brackets, as shown.

Refer to page 12 for solar panel wiring connections

Refer to page 13 for general solar panel mounting.

Refer to page 14 for information on determining your specific mounting angle.

Run rigid steel conduit from the solar panel to the 3/4" AC knockout located at the bottom of the siren case assembly. A section of up to 24 inches of metal bonded seal tight conduit may be utilized where conduit connections to the solar panel or electronic cabinet are not conveniently accomplished with rigid steel conduit and fittings. This conduit should be sealed to prevent insects and pests from entering the siren case assembly.

Fig. 7: Solar Panel Wiring Connections

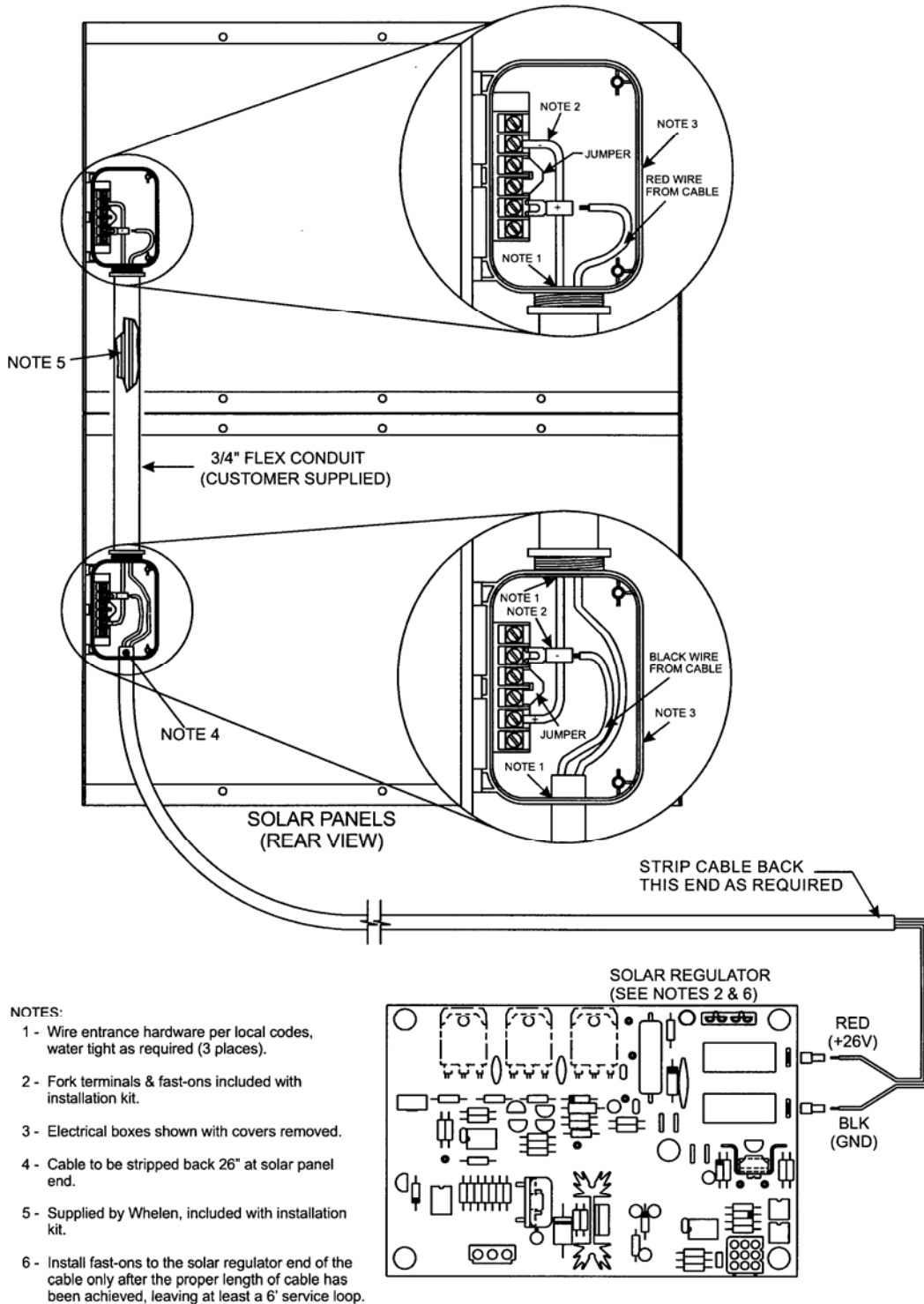
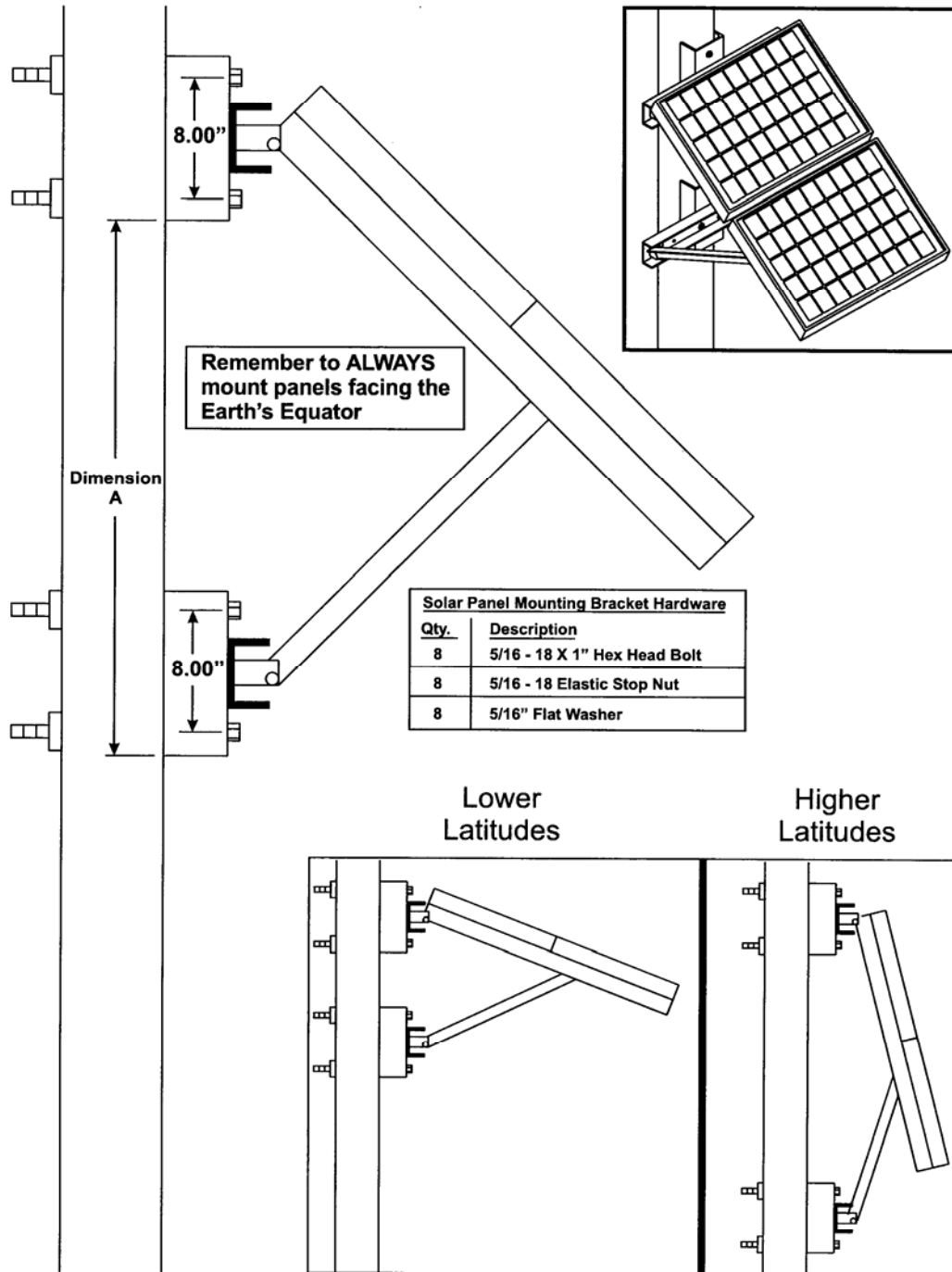

Fig. 8: Solar Panel Mounting Views



e) Determining Solar Panel Mounting Angle

1. Determine the *LATITUDE* of your location.
2. Find your *Latitude* on the table below and not the corresponding *Tilt Angle*.

Latitude

Tilt Angle

0° to 9°

75° = Tilt Angle

10° to 20°

85° minus LATITUDE = Tilt Angle

21° to 45°

80° minus LATITUDE = Tilt Angle

46° to 65°

75° minus LATITUDE = Tilt Angle

66° to 75°

10° minus LATITUDE = Tilt Angle

3. Locate your TILT ANGLE in the list below. For every TILT ANGLE, there is a corresponding “Dimension A”. “Dimension A” represents the distance from the bottom of the upper mounting bracket to the bottom of the lower mounting bracket.

example 1:

Location **Latitude** is 30°

80° - 30° = 50° Tilt Angle

50° Tilt Angle = 33.60” Dimension A

example 2:

Location **Latitude** is 7°

7° = 75° Tilt Angle

75° Tilt Angle = 15.54” Dimension A

Tilt Angle	Dimension A (inches)	Tilt Angle	Dimension A (inches)	Tilt Angle	Dimension A (inches)
10	50.49	32	43.71	54	30.93
11	50.34	33	43.24	55	30.24
12	50.16	34	42.77	56	29.54
13	49.97	35	42.28	57	28.84
14	49.77	36	41.78	58	28.13
15	49.55	37	41.26	59	27.41
16	49.32	38	40.74	60	26.69
17	49.08	39	40.20	61	25.96
18	48.82	40	39.65	62	25.23
19	48.54	41	39.10	63	24.50
20	48.25	42	38.53	64	23.76
21	47.95	43	37.95	65	23.01
22	47.63	44	37.36	66	22.27
23	47.30	45	36.75	67	21.52
24	46.95	46	36.14	68	20.77
25	46.59	47	35.52	69	20.02
26	46.22	48	34.89	70	19.27
27	45.83	49	34.25	71	18.52
28	45.43	50	33.60	72	17.77
29	45.02	51	32.95	73	17.02
30	44.60	52	32.28	74	16.28
31	44.16	53	31.61	75	15.54

Section IV:

Wiring

a) Siren Connections

The type of speaker harness you receive depends on the number of speaker cells present. For systems consisting of 1 to 5 speaker cells, a 5-pair harness cable is provided. This cable has **11 BLACK** wires numbered 1 to 11 and 1 **GREEN/YELLOW** wire. The wires are designated as follows:

Wires with equal No. go to ground
Wires with unequal No. go to +

In systems with unused wires, dress the unused wires so they are out of the way. Do not cut these wires, as they can be used to replace damaged wires in the future.

NOTE:

The following procedure provides the information necessary for successfully connecting the siren harness wires to their designated amplifiers. Depending upon the distance between the siren base and the electronic cabinet, there will be varying lengths of wire remaining in the cabinet. It is the installer's responsibility to properly trim and dress these wires in a fashion that not only leaves the wires organized, but also includes a service loop of suitable length.

1. Locate the siren wiring harness where it enters the electronic cabinet.
2. Locate the **BLACK** wires marked 1 & 2 on their insulation. These wires are designated for connection to siren amplifier 1.
3. Route these wires through the cabinet's wire loom and connect to Amp 1 (see "Fig. 10: Rotor Control and Siren Amplifier Connections" on page 17).
4. Repeat steps 2 and 3, substituting the appropriate number for all remaining amplifiers.
5. When all amplifiers have been wired, install loom cover.
6. Route rotor cable through the wire loom to the rotor control.
7. Locate the 11-position Phoenix connector included with your system. Insert the rotor control wires into this connector as follows:

Position	Color	Position	Color
1	RED (14 AWG)	7	ORANGE (20 AWG)
2	BLACK (14 AWG)	8	GREY (20 AWG)
3	BROWN (20 AWG)	9	VIOLET (20 AWG)
4	BLUE (20 AWG)	10	RED (20 AWG)
5	GREEN (20 AWG)	11	BLACK (20 AWG)
6	YELLOW (20 AWG)	12	WHITE (spare/20 AWG)

7. Insert this connector into the receptacle marked "RC2" on the rotor control.

Fig. 9: Rotor Control and Siren Amplifier Connections

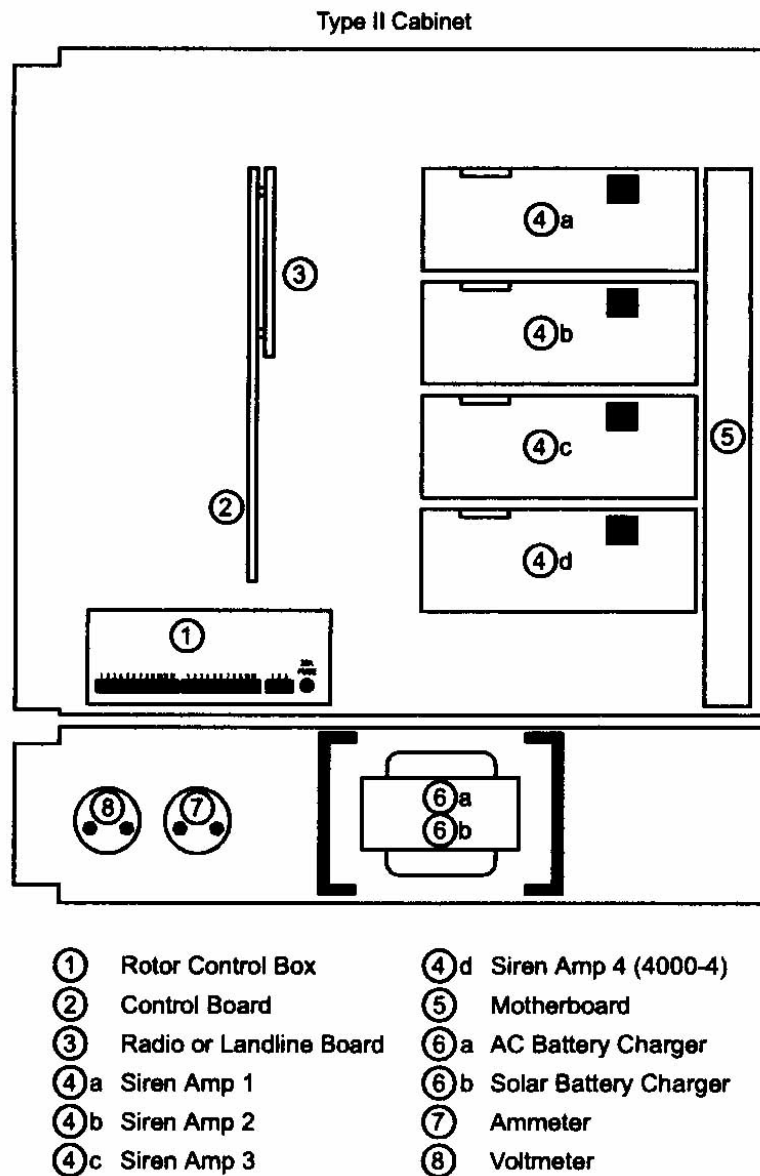

b) AC Wiring

An AC Service (Single Phase only) with an acceptable disconnect is required. A 15 amp (minimum) 120 VAC circuit is recommended.

Locate the service on the pole according to local codes, taking care that the service entrance will meet height requirement once the pole is set into place.

The WPS4000 Series siren includes a 15 amp, 120 VAC outlet. The cabinet's battery charger plugs into one of the receptacles. The remaining receptacle is available for use by service personnel (see "Fig. 11: AC Outlet Installation" on page 19).

NOTE:

A section of up to 24 inches of metal bonded seal tight conduit may be utilized where conduit connections to the siren case assembly are not conveniently accomplished with rigid steel conduit and fittings.

Each WPS4000 Series siren system is supplied with a lightning arrestor which is to be installed on the AC service. Local codes should be reviewed and followed to establish the connection of this device on the primary or secondary side of the disconnect.

NOTE:

The location of the siren site should be reviewed for the quality of the AC service. AC power sources that are subject to excessive power surges or transients are not acceptable.

The AC charger is simply plugged into an AC duplex outlet (factory included) installed as follows:

1. Remove the cover from the 4" x 4" box.
2. Position the 3/4" knock-out in the box above the 3/4" knockout in the cabinet.
3. Attach a flex fitting (not included) through the cabinet and the box. This will secure the box to the cabinet.
4. Connect the AC service to the leads on the cover assembly.
5. Attach the cover to the box.
6. Attach ground wire (GREEN) to cabinet ground stud above the installed outlet.

Fig. 10: AC Outlet Installation

c) Batteries

1. Make sure that the system battery switch is in the OFF position.
2. Install the batteries included with your system and connect them as shown in the illustration representing your cabinet type.

MAKE SURE TO OBSERVE THE POLARITY OF THE TERMINALS BEFORE MAKING ANY CONNECTIONS.

NOTE:

For battery wiring, DC wiring conventions are used (BLACK is ground (-)).

See “Fig. 12: Battery Connections (Type II Cabinet)” below.

3. Rotate the system battery switch to the ON position.
4. Plug the battery charger into AC power
5. Verify system operation as outlined in the system maintenance check list. (See pp. 22 and 23 in The Operating and Troubleshooting Manual).

Fig. 11: Battery Connections (Type II Cabinet)

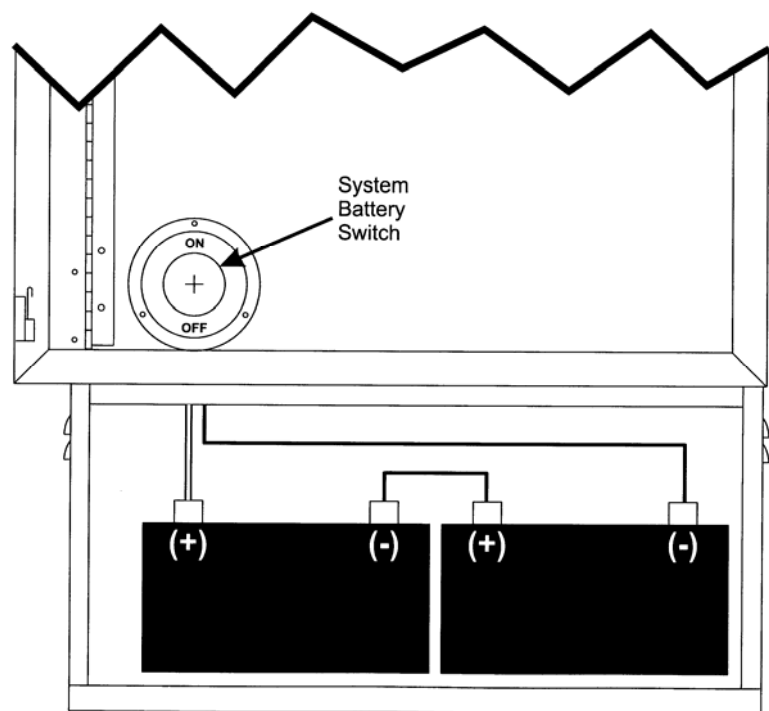

d) Landline (optional)

As an option the WPS4000 Series siren may be remote controlled by either landline or RF link. Either method communicates via a DTMF protocol. Remote control may be one-way or two-way. The one-way option simply controls the WPS4000 siren, while the two-way option controls the WPS4000 siren and reports WPS4000 status back to a central control point.

Fig. 12: Landline Wiring

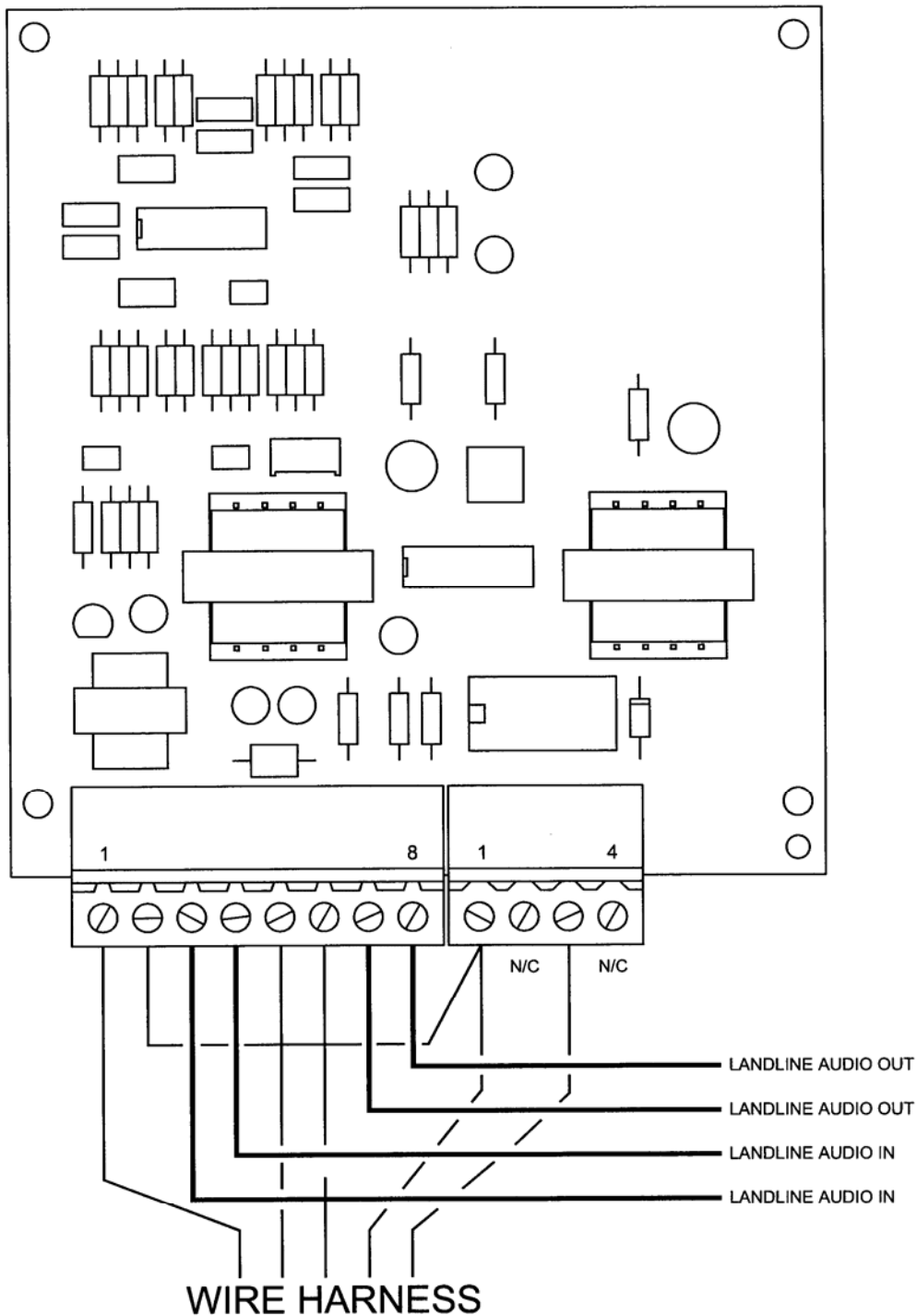

Section V:

System Test

After installation of the WPS4000 station has been completed, a basic system check is recommended to confirm that the system is functioning properly. Before initiating these tests, locate the system LEDs on the main control board mounted to the cabinet door (see “Fig. 13: System LED Diagnostic Indicators” on page 21).

1. Confirm that the ACTIVE light on the control board is flashing at a rate of a 1/2 second on and a 1/2 second off.
2. Press the SI TEST® button on the siren front panel and check to make sure that all the siren amplifier diagnostic LEDs illuminate for 5 seconds. These LEDs are located on the front of the cabinet door. Also verify that the speaker rotated during the test.
3. After the amplifier LEDs turn off, check to see if the AC, DC, PARTIAL and FULL LEDs are on.

If one of your amplifier lights did not illuminate during this test then refer to the procedure below to troubleshoot the problem.

This procedure may be used when the Partial or full LEDs indicate a failure.

NOTE:

In order for a “Full indication to be valid, the “Partial” LED must also be on.

1. Press the SI TEST® button located on the front panel of the electronic cabinet. Each amplifier has a red LED diagnostic indicator that is visible on the front panel (see “Fig. 14: Electronic Cabinet Front Panel (Type II)” on page 23).
2. A SI TEST® will cause each amplifier’s diagnostic indicator to turn on. If one or more do not turn on, proceed to step 3. If all indicators turn on, the siren amplifiers are functioning properly.
3. Open the front panel and remove the speaker driver from the amplifier that did not light and install it onto an amplifier that did light. For example: If amplifier 1 did not light but amplifier 2 did, install speaker 1 on amplifier 2 and speaker 2 on amplifier 1. This will indicate if the failure was with the speaker or the amplifier. For more information on troubleshooting the system, refer to the Advanced Troubleshooting Manual.

Fig. 13: System LED Diagnostic Indicators

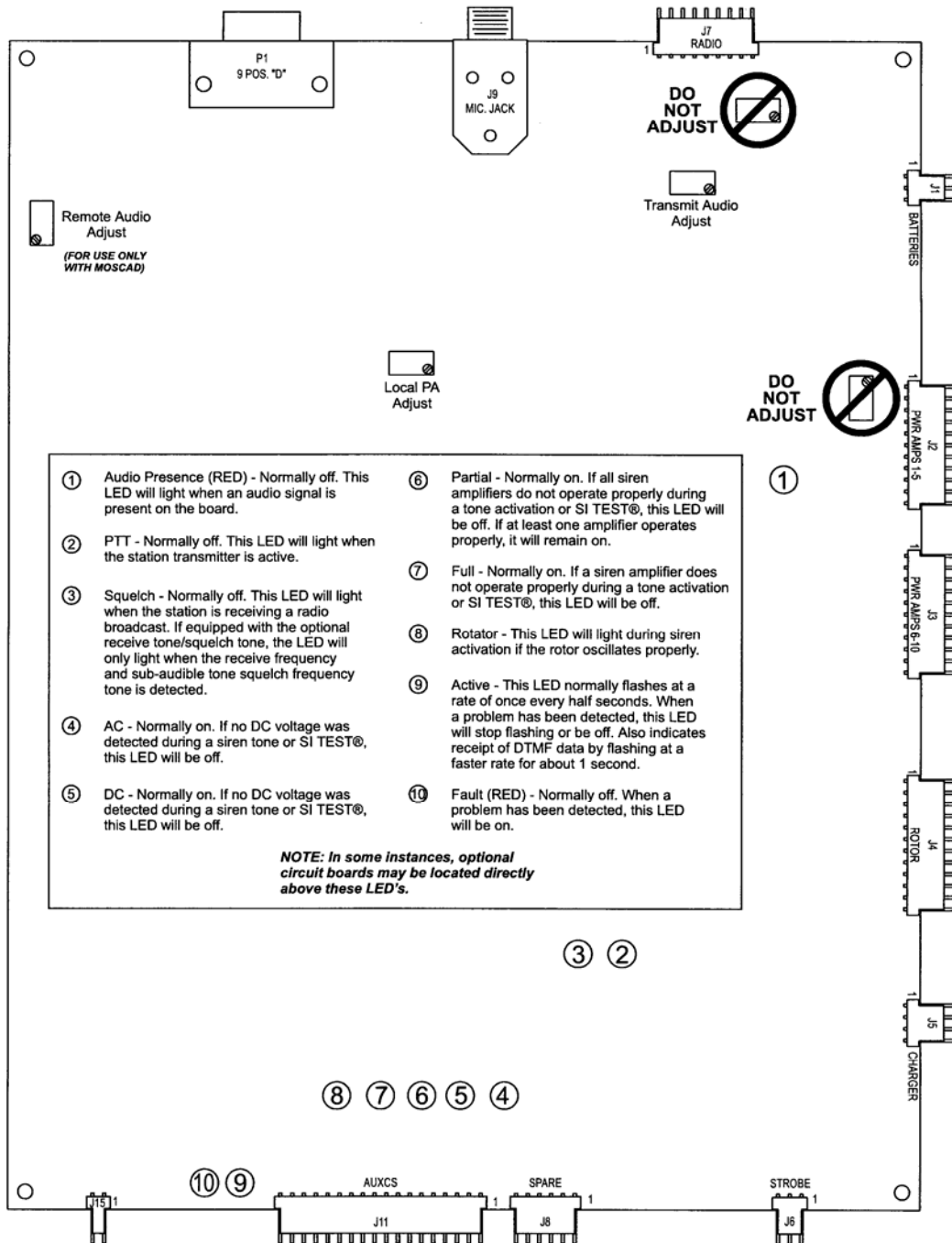

Fig. 14: Electronic Cabinet Front Panel (Type II)

